



## Roller banner | Basic | 85 × 200 cm

### Final Format (TrimBox):

850 × 2250 mm

### General information:

- Equipped as a complete system (Print and housing), including carrying bag.
- Aluminium housing with two adjustable feet.
- Suitable for indoor use and shorter applications.
- 4/0-colour printed banner.
- For a deep black colour applications it is recommended to apply the following colour setting:  
C 60 % | M 40 % | Y 20 % | K 100 %.
- Further information on the product, tension spring adjustment and assembly instructions can be found on the following pages of this data sheet.
- Please provide one PDF with a single page.

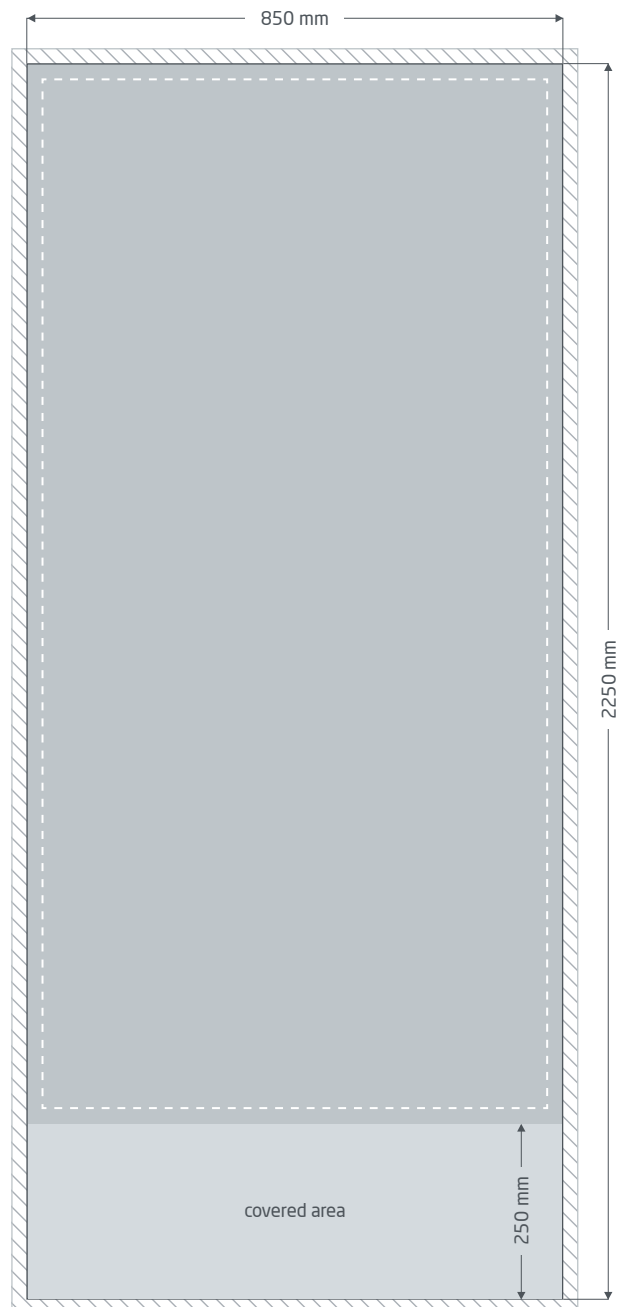

#### Bleed margin: min. 10 mm

Elements that extend to the edge of the page require a bleed margin. This area can be cut off during further processing.



**Final Format:** Size of the visible banner.



#### Safety clearance: min. 40 mm

Due to manufacturing tolerances, important text and image elements should have a safety clearance from the edges of the final format.



**Covered area:**

This part of the print is hidden in the cassette.

## Assembly instructions » Roller banner Basic

### ✔ Included in delivery



Carrying bag



Cassette with printed banner



Bar

### ✔ Assembly

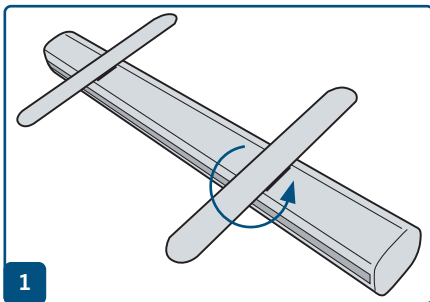

Adjust the stands in such a way that the roller banner stands securely.

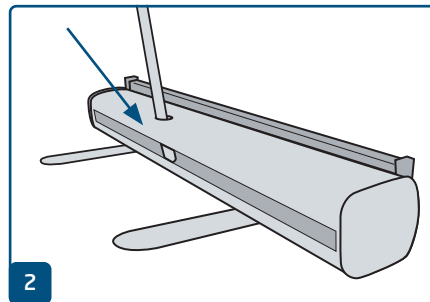

Unfold the three-part bar and plug it together. The lower part of the bar (without the plastic cap) is inserted into the hole in the housing.

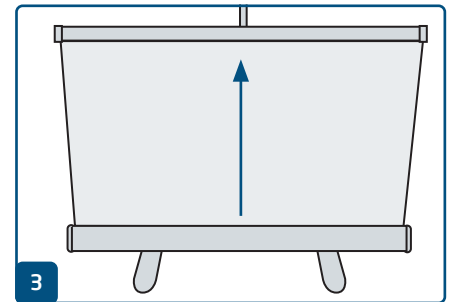

Pull the printed sheet out of the base straightly.

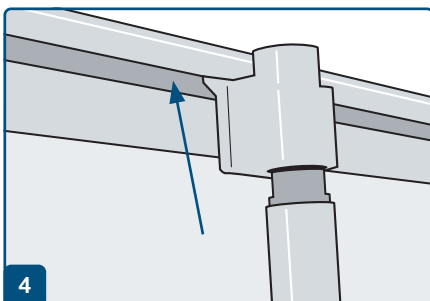

Snap the plastic holder on the top of the bar into the clamping strip. This is easier if you stand behind the cassette and tilt it slightly at an angle when pulling out the printed banner.

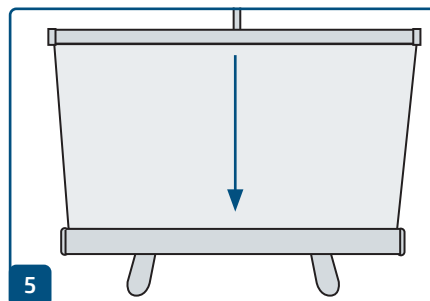

When dismantling, allow the printed banner to retract as straight as possible.

## Restore spring tension » Roller banner Basic

### Readjust spring tension

If the tension of the spring core of the roll-up has been reduced, your banner will no longer be pulled all the way to the clamping bar in the cassette. Restore the spring tension in a few steps:

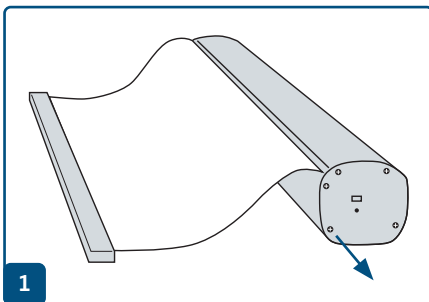

Loosen the screws.

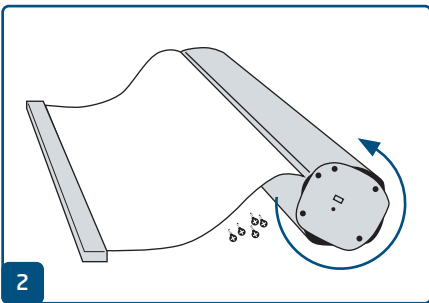

Turn the splint with the cover flap against the retraction direction a few times until the banner is completely retracted. Hold the flap firmly while doing this.

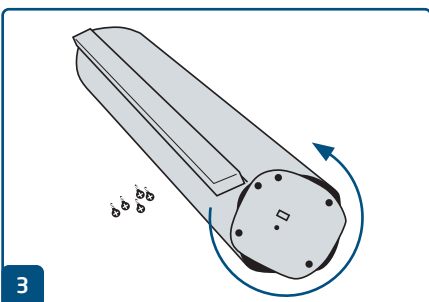

Turn the splint with the cover flap four more full turns in the same direction.

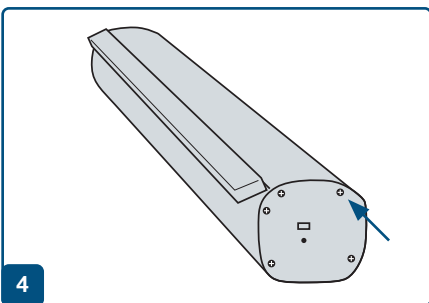

Screw the cover flap tight again. The original spring tension is restored and the automatic complete retraction of the banner works again.

## Guide on preparing print data

In order to achieve an optimal print result, please consider the following items when creating your print data:

### File format

Please send us a PDF or JPG file that is ready to print. We recommend that you create a PDF file according to the PDF/X-1a, PDF/X-3 or, preferably, the PDF/X-4 standard.

### Colour space and ink coverage

All elements of the document should be created in CMYK mode. We will automatically convert data created in another colour mode (e.g. RGB, LAB, spot colours) to CMYK. We do not assume any liability for resulting colour deviations or non-display of objects, especially in connection with transparencies or unknown special colours. Furthermore, please provide your print data with the corresponding ICC profiles for standardised offset printing. For coated papers use the colour profile "PSOcoated\_v3.icc" and for uncoated papers the profile "PSOuncoated\_v3\_FOGRA52.icc".

Please create grey areas and black texts exclusively in the black channel. Objects with a total colour application of over 320%, exceeding the limit for printing, will be reduced to this 320% total colour application for production reasons.

### Resolution of images and graphics

Generally, we recommend a resolution of at least 250 ppi (dpi), and at least 1,200 ppi (dpi) for line art.

### Page format, page alignment, and page bleed

Please make the page format and page orientation equal for all sides and according to your desired print job. Elements that extend to the edge require a bleed margin. Furthermore, we recommend that you maintain a safety clearance at the edge of your document by not placing any text or important elements due to possible manufacturing tolerances. If the page format or page orientation in your print data differs from the requirements listed herein, we will place your template centred and unscaled in the ordered page format and we will notify you thereof before you give the approval for printing. We cannot accept any liability for resulting complaints.

### Fonts

Please embed all the fonts that you use in your print file. We will not replace missing fonts. For optimum readability, we recommend a minimum font size of 5 points.

### Lines

The line weight of graphics and text outlines should be at least 0.2 pt. We automatically thicken excessively thin lines to this minimum printable size. Please note that this can also cause lines created with 0 pt to become visible or thicken text outlines that are too narrow.

### Overprinting, non-printing elements and layers

Please remove all non-printing elements from your document. PDF files should not contain any layers. Check if the overprinting settings are correct.

## Format adjustment

During the ordering process and as part of the selected data check, we check your print data to see if the page format of your print data matches that of the ordered product, among other things. Only the "TrimBox" is important in this case. You can freely define the size of the possible BleedBoxes according to your needs.

### Final Format (TrimBox):

The TrimBox describes the trimmed final format of a page.

### BleedBox:

The BleedBox defines the bleed of a page. With a bleed of 3 mm, the BleedBox will be 3 mm larger all around than the final format.

You can check the TrimBox of your PDF file using the **Adobe Acrobat Reader** and **Adobe Acrobat** programs. Unlike Acrobat, Adobe Reader has very limited functionality. For instance, you cannot alter PDF documents with Adobe Reader. You must use Acrobat to do so.

You can display the TrimBox or final format in both programs as follows: Open the "Presets" in the menu and from there, activate "Page display" » "Page contents and information", activate the "Show art, final format, and BleedBox" menu item. Afterwards, the TrimBox will be displayed with a red border and the BleedBox with a blue border in the corresponding PDF file.

If there are discrepancies between the page formats of the ordered product and their print data, we adjust the format. In other words, we place your data centrally and unscaled in the ordered page format and notify you both in the test report of the data check and in a separate window before the order is completed.

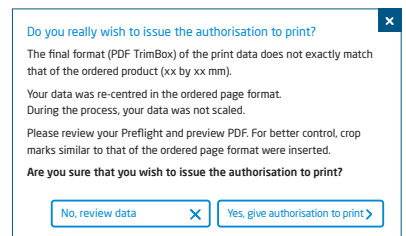
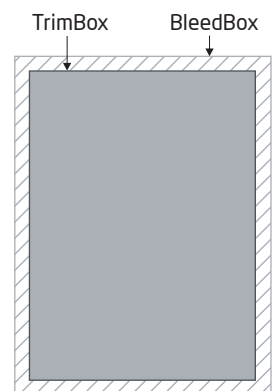

my\_printfile.pdf

Print data check successfully completed with messages ([Preview](#) / [Test report](#))

In our prepared, low-resolution preview file, you can check the status of your file. If the format is adjusted, we always add crop marks for you in this preview.



We do not check the contents of your data at all. The print data is checked automatically. Please make sure that you always adhere to the instructions of the data check print area in the online website. We recommend that you use "advanced data check". We assume no responsibility for problems arising due to failure to adhere to this data sheet and the data handling guidelines on our website!