



## Coaster | hexagonal | 100 × 87 mm | single-sided printing

**Final Format (TrimBox):**  
100 × 87 mm

**General information:**

- Please provide print data without the stamping mould.
- Please do not make your text smaller than 7pt.
- Please be mindful of the dot gain! (see page 2 of this PDF)
- Please provide one PDF with a single page.

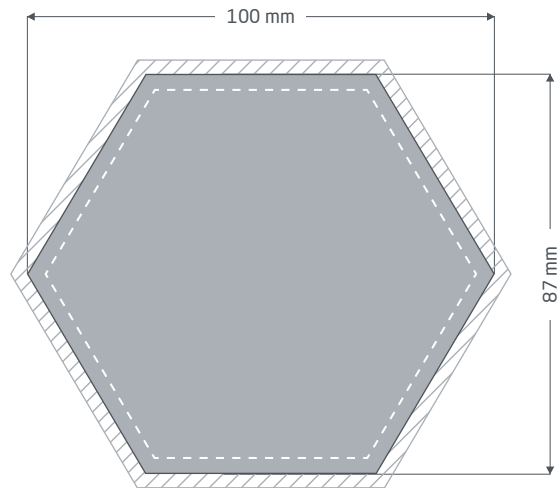

Front side (PDF page 1)



**Bleed margin: min. 2 mm**

Elements that extend to the edge of the page require a bleed margin. This area can be cut off during further processing.



**Safety clearance: min. 3 mm**

Due to manufacturing tolerances, important text and image elements should have a safety clearance from the edge of the final format.



**Final Format:** Size of the finished product

## Product-specific data preparation » Coaster

---

### **Format adjustment**

Please always follow the instructions in the test report. If you provide an incorrect page format, incorrect TrimBox or incorrect page orientation, we will place your data centred and unscaled in the ordered page format and inform you before you authorise the printing.

---

### **Dot gain**

Please observe a dot gain of 20% due to the specific paper. The same colours should accordingly be created with a deviation of at least +/- 20% to achieve a difference. Consequently, there would be no visible difference between text with 90% black that is created on a surface with 80% black.

---

## Guide on preparing print data

In order to achieve an optimal print result, please consider the following items when creating your print data:

### File format

Please send us a PDF or JPG file that is ready to print. We recommend that you create a PDF file according to the PDF/X-1a, PDF/X-3 or, preferably, the PDF/X-4 standard.

### Colour space and ink coverage

All elements of the document should be created in CMYK mode. We will automatically convert data created in another colour mode (e.g. RGB, LAB, spot colours) to CMYK. We do not assume any liability for resulting colour deviations or non-display of objects, especially in connection with transparencies or unknown special colours. Furthermore, please provide your print data with the corresponding ICC profiles for standardised offset printing. For coated papers use the colour profile "PSOcoated\_v3.icc" and for uncoated papers the profile "PSOuncoated\_v3\_FOGRA52.icc".

Please create grey areas and black texts exclusively in the black channel. Objects with a total colour application of over 320%, exceeding the limit for printing, will be reduced to this 320% total colour application for production reasons.

### Resolution of images and graphics

Generally, we recommend a resolution of at least 250 ppi (dpi), and at least 1,200 ppi (dpi) for line art.

### Page format, page alignment, and page bleed

Please make the page format and page orientation equal for all sides and according to your desired print job. Elements that extend to the edge require a bleed margin. Furthermore, we recommend that you maintain a safety clearance at the edge of your document by not placing any text or important elements due to possible manufacturing tolerances. If the page format or page orientation in your print data differs from the requirements listed herein, we will place your template centred and unscaled in the ordered page format and we will notify you thereof before you give the approval for printing. We cannot accept any liability for resulting complaints.

### Fonts

Please embed all the fonts that you use in your print file. We will not replace missing fonts. For optimum readability, we recommend a minimum font size of 5 points.

### Lines

The line weight of graphics and text outlines should be at least 0.2 pt. We automatically thicken excessively thin lines to this minimum printable size. Please note that this can also cause lines created with 0 pt to become visible or thicken text outlines that are too narrow.

### Overprinting, non-printing elements and layers

Please remove all non-printing elements from your document. PDF files should not contain any layers. Check if the overprinting settings are correct.

## Format adjustment

During the ordering process and as part of the selected data check, we check your print data to see if the page format of your print data matches that of the ordered product, among other things. Only the "TrimBox" is important in this case. You can freely define the size of the possible BleedBoxes according to your needs.

### Final Format (TrimBox):

The TrimBox describes the trimmed final format of a page.

### BleedBox:

The BleedBox defines the bleed of a page. With a bleed of 3 mm, the BleedBox will be 3 mm larger all around than the final format.

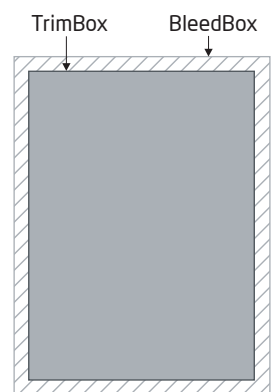

You can check the TrimBox of your PDF file using the **Adobe Acrobat Reader** and **Adobe Acrobat** programs. Unlike Acrobat, Adobe Reader has very limited functionality. For instance, you cannot alter PDF documents with Adobe Reader. You must use Acrobat to do so.

You can display the TrimBox or final format in both programs as follows: Open the "Presets" in the menu and from there, activate "Page display" » "Page contents and information", activate the "Show art, final format, and BleedBox" menu item. Afterwards, the TrimBox will be displayed with a red border and the BleedBox with a blue border in the corresponding PDF file.

If there are discrepancies between the page formats of the ordered product and their print data, we adjust the format. In other words, we place your data centrally and unscaled in the ordered page format and notify you both in the test report of the data check and in a separate window before the order is completed.

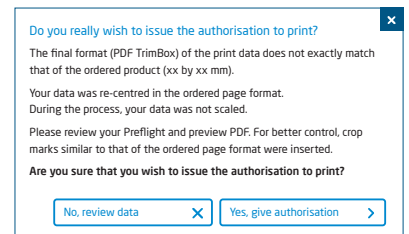

### my\_printfile.pdf

Print data check successfully completed with messages ([Preview](#) / [Test report](#))

In our prepared, low-resolution preview file, you can check the status of your file. If the format is adjusted, we always add crop marks for you in this preview.



We do not check the contents of your data at all. The print data is checked automatically. Please make sure that you always adhere to the instructions of the data check print area in the online website. We recommend that you use "advanced data check". We assume no responsibility for problems arising due to failure to adhere to this data sheet and the data handling guidelines on our website!